

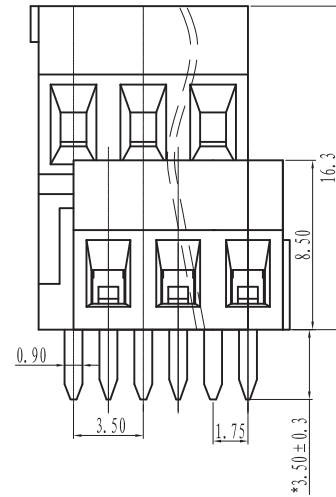

# CIXI WANJIE ELECTRONIC CO., LTD

THE SPEC SHEET

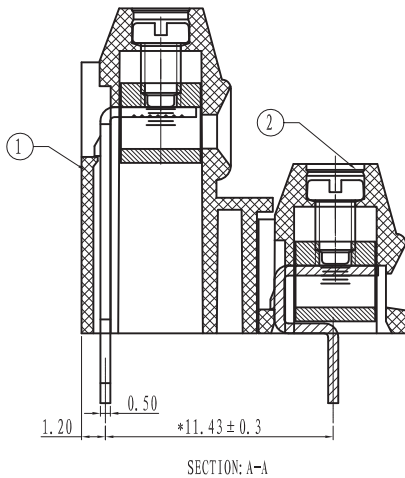
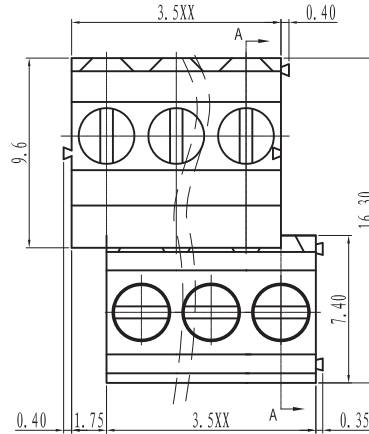
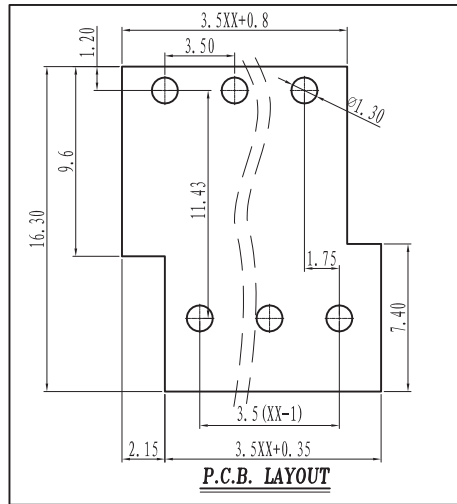

## Electrical

|                       |                |                    |
|-----------------------|----------------|--------------------|
| Standard              | UL             | IEC                |
| Rated voltage         | 300V           | 250V               |
| Rated current         | 10A            | 13.5A              |
| Contact resistance    | 20mΩ           |                    |
| Insulation resistance | 500MΩ/DC500V   |                    |
| Wire range            | 28~16AWG       | 1.0mm <sup>2</sup> |
| Wrth standing voltage | AC 2000V/1 Min |                    |

## Mechanical

|               |                   |
|---------------|-------------------|
| Torque        | 0.2Nm(1.8Lb.in)   |
| Steip Length  | 4-5mm             |
| Temp.Range    | -40°C~+105°C      |
| MAX Soldering | +250°C, for 5 Sec |

## Dimensions

|       |           |
|-------|-----------|
| Pitch | 3.5mm     |
| Poles | 2x2~2x24p |

## Material

|            |                       |
|------------|-----------------------|
| Housing    | PA66, UL94V-0         |
| Screws     | M2.0 Steel, Zn plated |
| Pin header | Brass, Tin plated     |
| Cage       | Brass, Ni plated      |

| linear dimension(Tolerances Standard GB/T 14486-2008) |      |              |               |               |               |               |                |                 |                 |                 | ≡     | —    | □            | //             | ⊥           |     |
|---|------|--------------|---------------|---------------|---------------|---------------|----------------|-----------------|-----------------|-----------------|-------|------|--------------|----------------|-------------|-----|
| variable range  | to 6 | over 6 to 10 | over 10 to 18 | over 18 to 30 | over 30 to 50 | over 50 to 80 | over 80 to 120 | over 120 to 160 | over 160 to 200 | over 200 to 250 | all   | to 5 | over 5 to 30 | over 30 to 120 | over 120 to |     |
| tolerance   | ±0.1 | ±0.14        | ±0.19         | ±0.25         | ±0.32         | ±0.43         | ±0.57          | ±0.72           | ±0.88           | ±1.05           | ±1.25 | 0.5  | 0.025        | 0.06           | 0.12        | 0.4 |

|                                 |    |      |    |       |     |                            |  |
|---------------------------------|----|------|----|-------|-----|----------------------------|--|
| UNITS                           | mm | SIZE | A4 | SCALE | 8:3 | THIRD ANGLE PROJECTION     |  |
| CIXI WANJIE ELECTRONIC CO., LTD |    |      |    |       |     |                            |  |
| TITLE                           |    |      |    |       |     | WJEK350A-3.5-2*XXP-1YY-00A |  |